



RAB-800 HYDRAULIC RETRACTABLE BOLLARDS (BUILT IN PUMP) | **RAB-800**

Optima RAB-800 built-in pump hydraulic retractable bollards are designed for high security vehicle entrances, military, industrial, governmental and commercial buildings or streets which are closed to vehicle traffic between certain hours of the day. RAB-800 can be installed as a single bollard as well as in group of bollards with the help of individual hydraulic unit.



SYSTEM FEATURES

MODEL	RAB-800
Raise and Lower Times	4-8 seconds (Emergency Fast Operation (EFO): 1.5 with charged accumulator)
Bollard Height	400-1000 mm (Standard: 800)
Bollard Diameter	219-273-324-355 mm
Power Failure	Manual hand pump
Material	ST 37 steel & AISI 316 Stainless Steel Sleeve
Motor Protection	Thermic breaker
Electric Motors Drive	With contactor
Operating Pressure	50-140 bar
Control Electronics	Optima Control Card
Keyboards	Desktop Keyboard
Power Consumption / Insurance Value	5.5kW - 11kW / 32A-3P-C FUSE-63A-3P-C FUSE
Environmental Conditions and Power Requirements	Between -15°C and +65°C, 95% non condensing humidity, 380V, three phase, 50-60 Hz (or 220V/440V/etc. , three phase, 50-60 Hz, optional by transformer)

ACCESSORIES

Accessories marked with (*) are optional.



- SCADA or any control system: It is possible to change and check the position of bollard with touch screen control panel, mobile devices (ios-android), computer, etc.*
- Red/green traffic lights with steel pole *
- Safety photocell *
- Stand and casing for safety photocell *
- Dual vehicle safety loop detector *
- Submersible drainage pump *
- Optima Cloud. To control barrier by mobile devices (ios-android), computer, etc. *
- Radio receiver & antenna *
- Radio transmitter *
- Wrong direction alarm *
- High speed alarm *
- Uninterrupted power supply (UPS) *

BODY MEASUREMENTS

FRONT VIEW

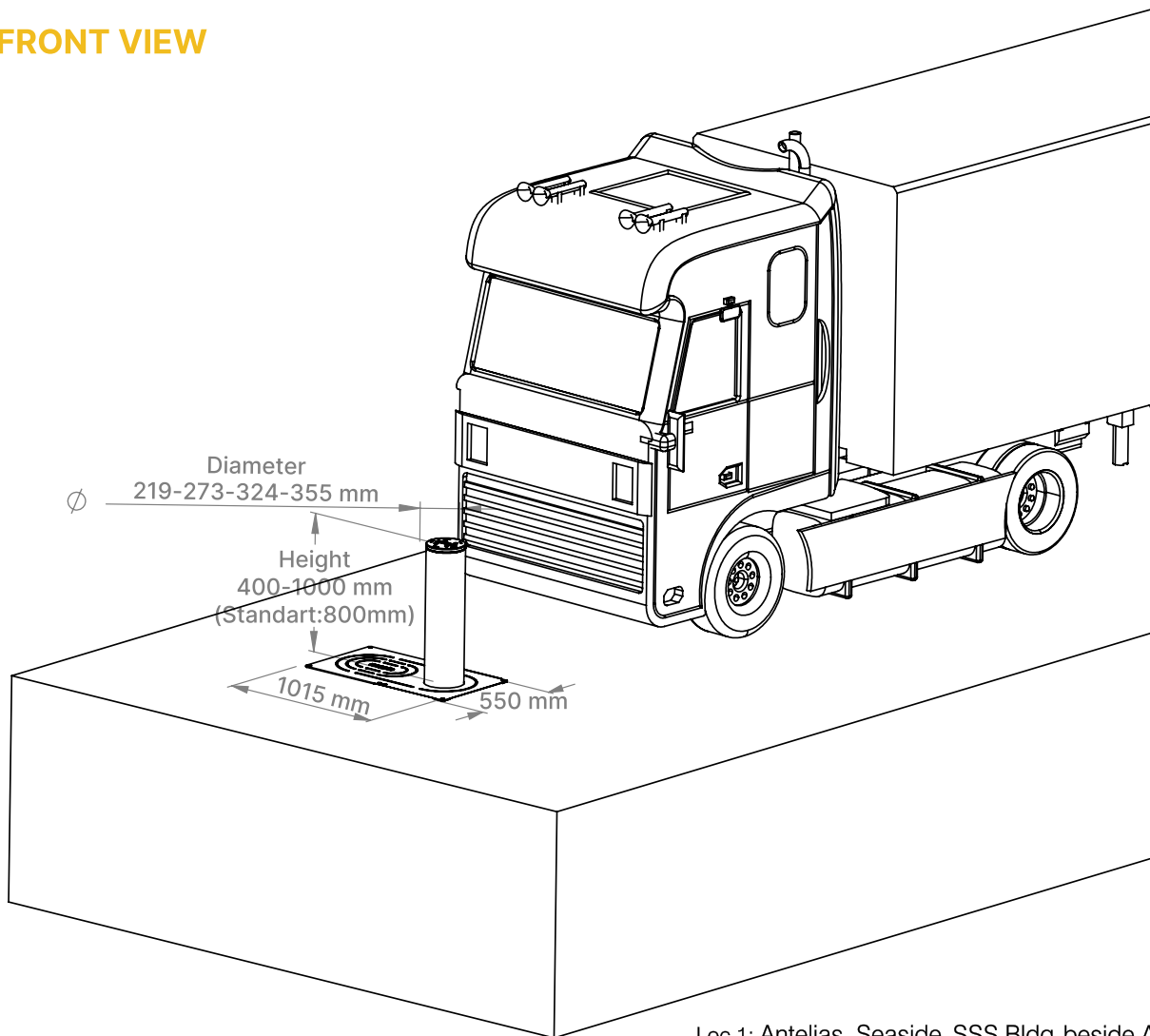

Loc 1: Antelias, Seaside, SSS Bldg, beside AISHTI.
Loc 2: Bchamoun, Behind Louise Wegmann, SSS Bldg.

Tel: +961 71 260 007
Email: sales@sss-lb.com
www.sss-lb.com