

# TOSHIBA

Leading Innovation >>>



## New ELBRIGHT

TOSHIBA **HIGH SPEED** ELEVATORS

# New ELBRIGHT

## TOSHIBA HIGH SPEED ELEVATORS

### **A new concept in high-speed elevators.**

Toshiba never stops introducing the latest technologies and polishing its high-speed elevator expertise. Toshiba proves this again with **New ELBRIGHT** : a new elevator for a new age. Toshiba engineering has combined to produce the world's first inverter-control high-speed elevator, with the high-efficiency control, energy efficiency, and quiet operation demanded by today's society.

#### **Providing environmentally conscious products (New ELBRIGHT)**

Toshiba elevator group is promoting the development of environmentally conscious products, which involves environmentally conscious product design, the assessment of environmental impact of products and disclosure of the environmental performance of products. Products are developed in compliance with the updated voluntary environmental performance standards.

#### **Product assessment and voluntary environmental standards for products**

In developing products, we conduct a product assessment across their life cycles from manufacturing, logistics and use to disposal and recycling in order to conduct product development and reduce the environmental impacts on the global environment.

Whereas product assessment is used to confirm the minimum necessary environmentally conscious requirements for product development, Voluntary Environmental Standards for Products have been established in Toshiba elevator group to create highly environmentally friendly products and those products complying with such Standards are released as environmentally conscious products.

#### ■ Specifications

Passenger	8~24persons
Rated capacity	600~1800kg
Rated speed	120~240m/min
Driving system	Traction (Gearless)
Control system	Inverter control

# Concept of New ELBRIGHT

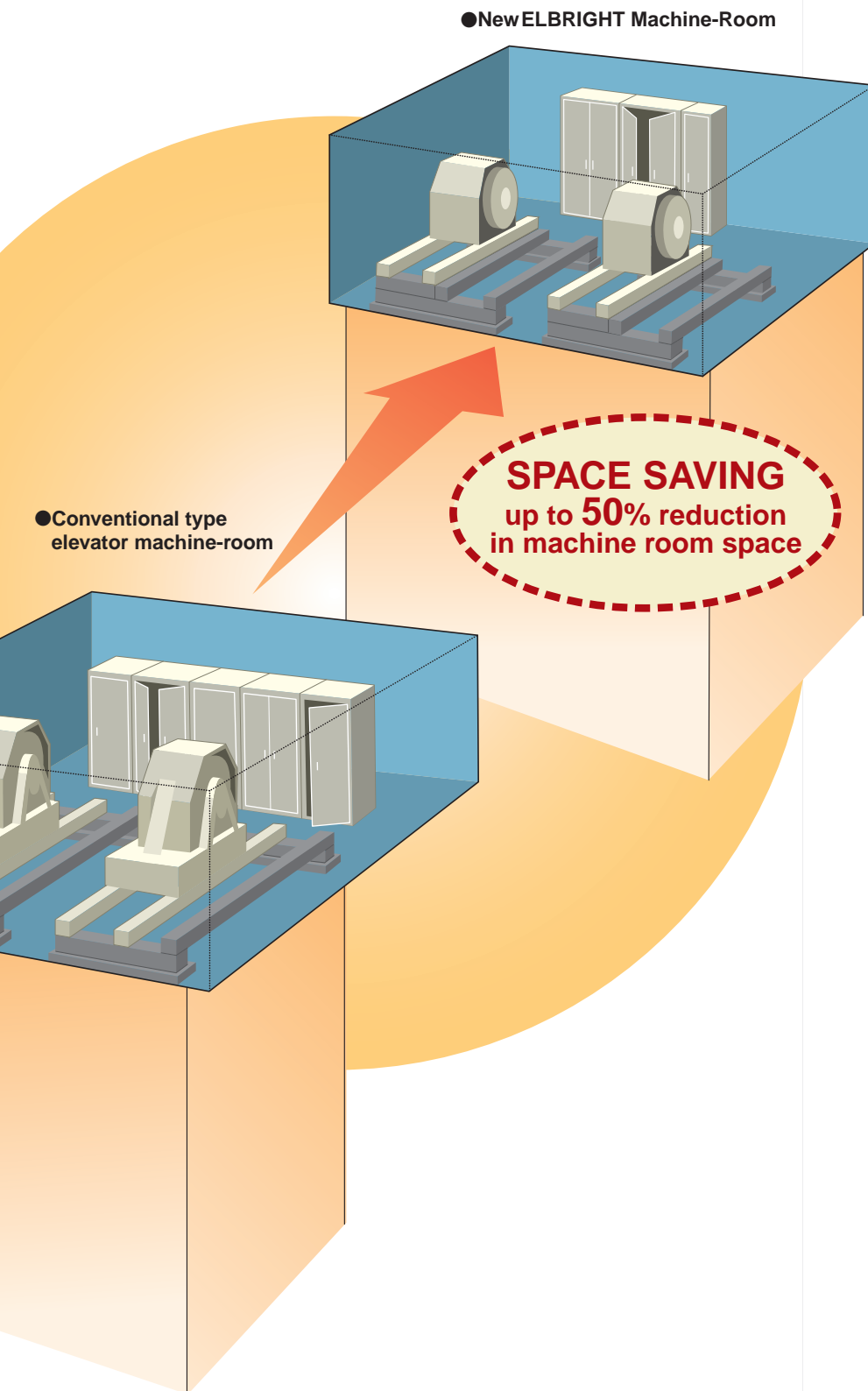

\*Comparison with New ELBRIGHT and conventional high-speed elevator.

## CONTENTS

### PRODUCT CONCEPT New ELBRIGHT Elevator technology .. ③~④

New technology

### THE GUIDE LINE-1 Traffic planning / Group control system .. ⑤~⑧

- 1-1 Deciding speed ..... ⑥
- 1-2 Deciding number of cars ..... ⑥
- 1-3 Deciding passenger capacity ..... ⑦
- 1-4 Deciding service floors ..... ⑦
- 1-5 Deciding the layout ..... ⑦
- 1-6 Operating system ..... ⑧
- 1-7 Group control system (EJ-1000series) ..... ⑧

Traffic planning/group control system

### THE GUIDE LINE-2 Soundproofing and harmonic distortion measures .. ⑩~⑭

- 2-1 Car soundproofing ..... ⑩
- 2-2 Noise from the elevator impacting the outside ..... ⑫
- 2-3 Measures against harmonic distortion ..... ⑭

Soundproofing and harmonic distortion measures

### THE GUIDE LINE-3 Installation plan / Power facility plan .. ⑮~⑳

- 3-1 Installation plan <Standard type> ..... ⑮
- 3-2 Installation plan <Compact machine room type> ..... ⑰
- 3-3 Hoistway section ..... ⑲
- 3-4 Power facility plan ..... ⑳
- Works by others ..... ㉒

Installation plan / Power facility plan

# New technology

A high-efficiency Traction machine and advanced inverter control are expanding the possibilities of

# New ELBRIGHT

New ELBRIGHT was developed to be the best possible elevator, both for the buildings in which it is installed and for the people who ride it. Every part of the elevator uses Toshiba's leading technologies, from the Traction machine and control system to the cars, doors, and drive system. New ELBRIGHT will greatly raise the value of the high-speed elevator.



## Concept and Energy Efficiency via Permanent Magnet Synchronous Motor

New ELBRIGHT employs a gearless Traction machine using a permanent magnet synchronous motor (PMSM), in place of the conventional induction motor. The PMSM uses a permanent magnet, which has a high magnetic flux density. This allows the Traction machine to be made smaller and lighter. Further more, since a permanent magnetic flux is established, there is no need to release magnetizing current. This and other advantages allow for highly efficient control, which helps to save energy.

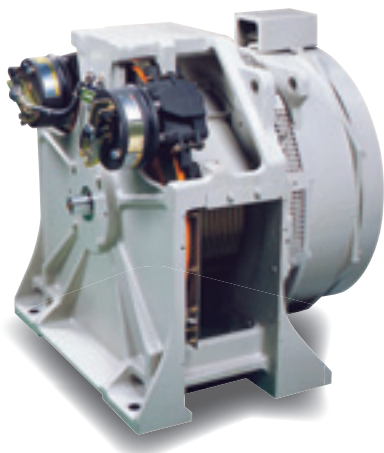

Permanent magnet synchronous motor

### ► Features of the New Traction Machine (comparisons with other Toshiba products)

Footprint	Approx. 60% lower
Height	Approx. 35% lower
Weight	Approx. 40% less
Motor efficiency	Approx. 5% higher

### ► Appearance comparison with conventional Traction machine

Conventional Traction machine  
Rated power : 40kw

New Traction machine  
Rated power : 45kw

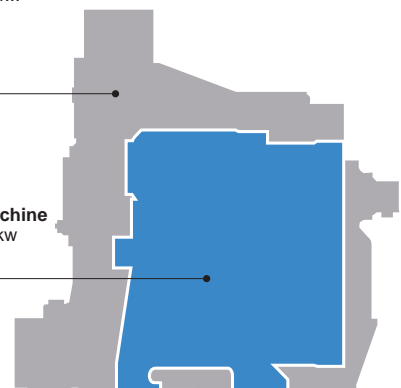

**PRODUCT CONCEPT**  
**2**

## Digital control provides high level of safety and improves control performance

New ELBRIGHT's control system features the "PP7", the latest inverter-control processor developed especially for power electronics. The PP7 improves control performance, and also enhances protection, maintenance and monitoring functionality. Incorporating a 32-bit central processing unit (CPU), peripheral devices, and multi-functional digital circuit in a single package, the PP7 decreases the size of the control system. Toshiba's unique Active Vibration Control and other features give the New ELBRIGHT a speedy, comfortable ride with waste-free, stable running.



**PRODUCT CONCEPT**  
**3**

## Regenerative electric power system

New ELBRIGHT introduces new regenerative electric power system "PWM-converter" for more energy-savings. The combination of PWM-converter and inverter system impressively creates regeneration electric power.

**PRODUCT CONCEPT**  
**4**

## A door drive system developed for smooth operation

The door drive system was developed for smooth operation. Combining the PP7 (the latest inverter-control processor), which is also employed by the Traction machine system, with a compact, high performance motor (permanent magnet synchronous motor). The door drive system not only operates smoothly, it is also lightweight and compact as well.

**PRODUCT CONCEPT**  
**5**

## Newly developed small and slim control panel realizes space-saving machine room.

Toshiba equips New ELBRIGHT's control system with newly developed small inverter unit. Also downsized peripheral equipments, integrated multifunctional digital line, small-sized control panel device and efficiently implemented layout realizes slim line control panel. Additionally, adequately considered design of control panel reduces working space for maintenance and thus space-saving machine room is achieved. Enhanced high-performance control, protective function, maintenance function and supervisory function are significant features and also Toshiba's original cutting edge technology "Active vibration reduction system" provides passengers with efficiently smooth and very comfortable ride.

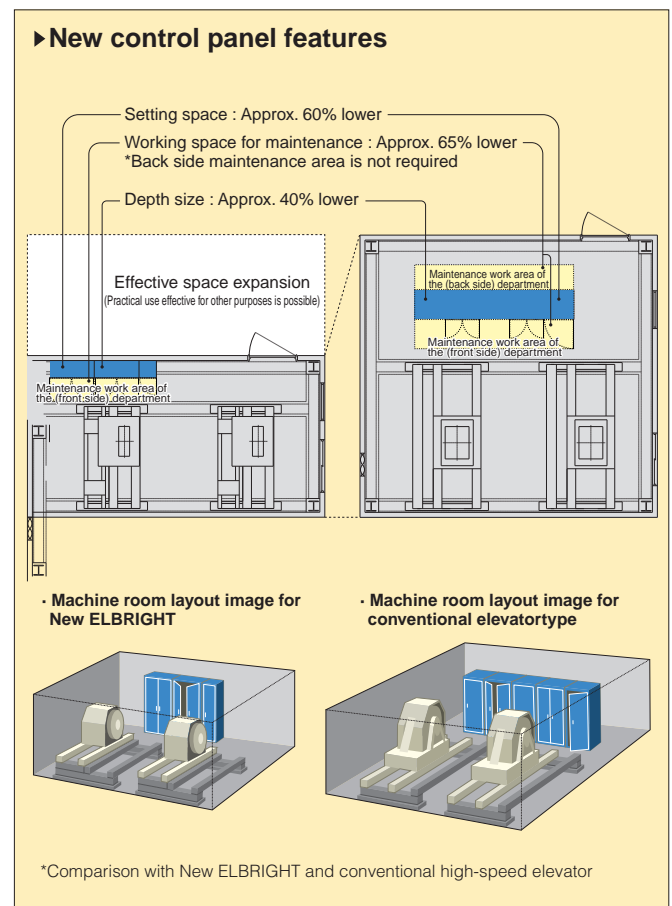

## **THE GUIDELINE-1**

# **Traffic planning / Group control system**

**Combining high-precision traffic planning with a building-specification operation plan, New ELBRIGHT offers the optimum system for your building.**

The system is able to distinguish between start of office hours, which represent the peak in elevator demand, lunchtime, at which there is a peak in demand for both ascending and descending, and normal service hours, and operate the most efficiently for each type of demand. Additionally, the latest group control system makes multiple elevators work systematically and in partnership, providing operation that is optimal for the building and comfortable for the passengers.

THE GUIDE LINE

## 1-1 Deciding speed

Elevator speed is generally determined by the number of floor in the building. A general guide is that it should no take more than 30 seconds to travel between the top and bottom floors. Using this basic value, the optimum speed for the building is selected by adding in such factors as the building's purpose, character, and service policy.

### Relationship between elevator speed and number of floors in building

**Example:**  
Setting the elevator speed in an office building

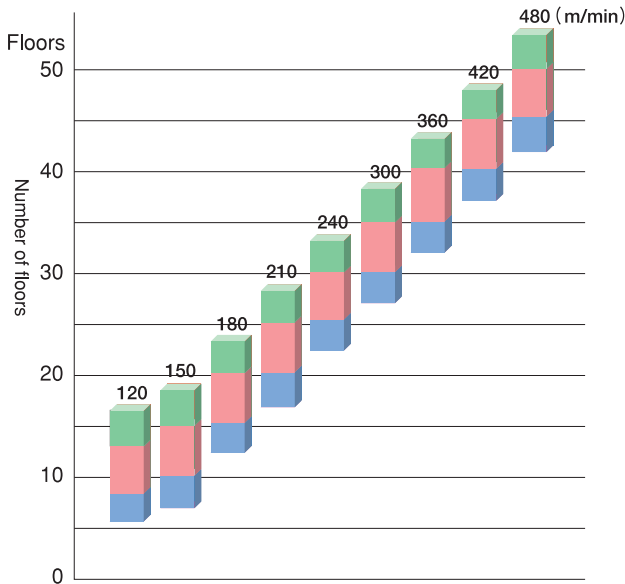

**Example:**  
Setting the elevator speed in a hotel

Economy-oriented  
Standard service  
Service-oriented

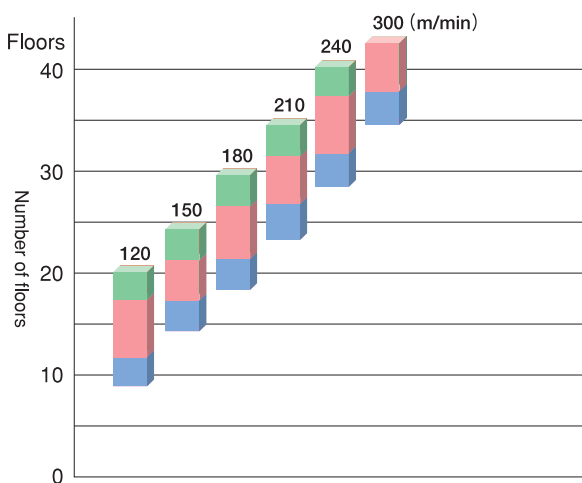

Note: We also support high-speed elevators with speeds exceeding 240 m/min. Please contact us for details.

THE GUIDE LINE

## 1-2 Deciding number of cars

### 1. Setting the number of cars

The number of cars is set in order to ensure that the transportation capacity and wait times are maintained within service levels at peak times when there is a concentration of passengers, such as in the mornings and evenings, and during lunchtime. Below is a general guideline for setting the number of elevator cars.

Service Level	Office Building	Hotel
	Number of users per elevator car	Number of rooms per elevator car
Service oriented	150~200passengers	90~120rooms
Standard service	200~250passengers	120~150rooms
Economy oriented	250~300passengers	150~180rooms

Note that for hotel, approximately two-thirds additional cars need to be allowed as service elevators are not included.

### 2. Traffic calculation

When deciding on the number of elevator cars, passenger capacity, and service floors, traffic calculation provides numerical data for study. The basic values for traffic calculation are shown below.

**Office building :**

Start of office hours set to be peak for traffic demand

Building Use	Transportation capacity ratio per 5 minutes	Average operation interval
Exclusive owned possession.	20~25%	Service oriented: 30 sec or less Standard service: 40 sec or less Economy oriented: 50 sec or less
Semi-exclusively owned bldg.	16~20%	
Government bldg.		
General office bldg.	11~15%	

**Hotel :**

Morning hours for check-ins and evening hours when guests leave or go to dinner set to be peak for traffic demand

Hotel Type	Transportation capacity ratio per 5 minutes	Average operation interval
City hotel	8~10%	40 sec or less
Resort hotel	10~13%	50 sec or less

### 3. Simulation

The building's traffic demand is simulated on a computer, getting a grasp of the state of service including such factors as average wait times and chance of long waits. Combining this simulation with the traffic calculation allows for more accurate planning. The computer mainly outputs normal service status, including peak times. The general base values for the simulation are as follows:

**Example : rental office building with demand concentration at 6% of building population per 5 minutes span (during office hours)**

- Average wait times : 30sec or less
- Chance of response within 30seconds : 70% or greater
- Chance of response after 60 seconds or more : 5% or less

# Traffic planning / Group control system

## THE GUIDE LINE

### 1-3 Deciding passenger capacity

Car passenger capacity must be planned with some leeway for peak times, such as mornings, evenings, and lunchtimes, when use is concentrated, as well as factoring in the nature of the building. We generally recommend the following type of plan:

1. For a small or mid-sized building, passenger capacity of 15 (load capacity of 1000kg) or higher.  
For a hotel or large office building, passenger capacity of 24 (load capacity of 1600kg) or higher.
2. Doors should open from the center, and the car entrance should be as wide as possible.
3. The car should be with in relation to its depth

## THE GUIDE LINE

### 1-4 Deciding service floors

Office buildings of more than 20 stories are generally zoned in order to decrease transportation times, improve rental rates, and the like. Zoning refers to dividing elevator service into a number of zones, and installing a dedicated elevator group for each zone. The following point must be taken into consideration in order to make effective use zones.

1. There should be about 10 to 15 floors per zone.
2. In consideration of future movements in tenant population, 2 floors of each service zone should overlap to allow for movement between floors.
3. Post the service floors clearly in order to keep people from getting on the wrong elevator.
4. Keep each elevator at the top or bottom of its service zone.

Unlike office buildings, we recommend staying with a single elevator group for hotels 40 stories or less in order to give top priority to ease of use, in consideration for first-time users. Using a single group does not make passengers select an elevator based on their destination floor, and is also more flexible than zoning, allowing for a number of elevators to be used for special service temporarily, without greatly affecting the passengers. Additionally, if the hotel has banquet halls, a wedding chapel or the like, it is preferable to install a dedicated escalator or elevator for these guests.

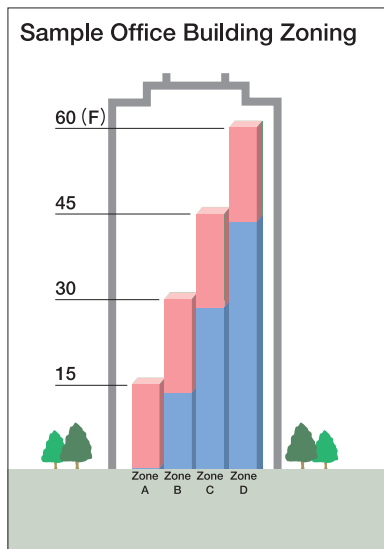

## THE GUIDE LINE

### 1-5 Deciding the layout

Elevator layout has a major influence on building functionality. Thus, the elevator must be laid out to be easy to use and fully harness the elevator's functionality.

1. Position the elevator so that any part of the floor can be reached with little walking, with a focus on lines of movement for traffic.
2. When installing several elevator groups, concentrate each group in a single location.
3. When lining elevators in a row, keep the number of elevators to no more than 4, with at most 8 meters between the elevators on each end.
4. If more than 4 elevators are installed, place them on facing sides of a hallway, with 3.5 to 4.5 meters between them.
5. It must be possible to see all elevators from anywhere in the hall. Avoid constructions with pillars in the elevator hall, and layouts with recessed elevator car entrances.
6. The elevator hall must be large enough that passengers do not spill out even during peak hours. In general, plan the elevator hall large enough to hold about 1/2 the combined maximum capacity of the cars (about 0.5 to 0.8 m<sup>2</sup> are required per passenger).

#### Recommend the examples of elevator layout

##### Line layout

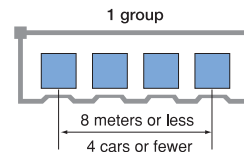

##### 2 groups or more

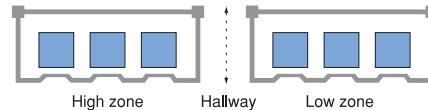

##### Facing layout

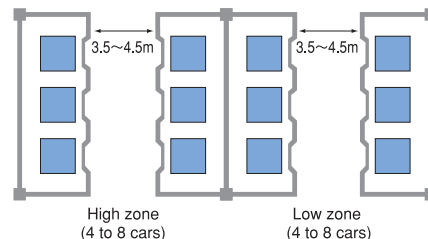

##### Alcove layout

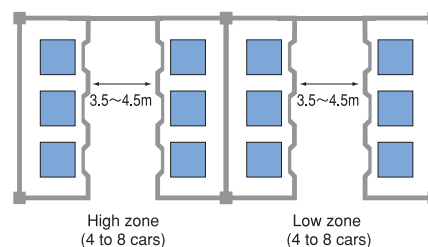



THE GUIDE LINE

## 1-6 Operating system

Select the operating system based on the building use, number of groups, etc.

Use No. Cars	Building owned by single company	Leased office building		Hotel		Condominium
		Large	Smaller	Large	Smaller	
1	Fully automated collective control	/	Fully automated collective control	/	Fully automated collective control	Fully automated collective control
2	Fully automated duplex collective control		Fully automated duplex collective control		Fully automated duplex collective control	Fully automated duplex collective control
3	Fully automated group control <b>EJ-1000FN</b> <b>EJ-100F</b>		Fully automated group control		Fully automated group control <b>EJ-1000FN</b> <b>EJ-100F</b>	Fully automated group control <b>EJ-1000FN</b> <b>EJ-100F</b>
4		Fully automated group control <b>EJ-1000FN</b> <b>EJ-100F</b>	Fully automated group control <b>EJ-1000FN</b> <b>EJ-100F</b>	Fully automated group control <b>EJ-1000FN</b> <b>EJ-100F</b>	Fully automated group control <b>EJ-1000FN</b> <b>EJ-100F</b>	
5-6		Fully automated group control <b>EJ-1000FN</b> <b>EJ-100F</b>	Fully automated group control <b>EJ-1000FN</b> <b>EJ-100F</b>	Fully automated group control <b>EJ-1000FN</b> <b>EJ-100F</b>	Fully automated group control <b>EJ-1000FN</b> <b>EJ-100F</b>	
7-8	Fully automated group control <b>EJ-1000FN</b>	Fully automated group control <b>EJ-1000FN</b>	Fully automated group control <b>EJ-1000FN</b>	Fully automated group control <b>EJ-1000FN</b>	Fully automated group control <b>EJ-1000FN</b>	

THE GUIDE LINE

## 1-7 Group control system (EJ-1000series)

### *EJ-1000FN*

The top model in the system, featuring the latest functionality

### *EJ-100F*

Standard system specifications, featuring highly sensitive allocation (fuzzy control) and peak support functions

### *EJ-10F*

Small-scale group control systems, featuring fuzzy control

#### ■ EJ-1000series specifications

Function	Fuzzy neural net control		
	Learning		
	Service reservation		
	Landing voice announcement system		
	Peak support (assigned operation)		
	High-sensitivity allocation (fuzzy control)		
	Expert system		
	Program modification		
No. Cars	3 to 8	3 to 6	3 to 4
Model	<i>EJ-1000FN</i>	<i>EJ-100F</i>	<i>EJ-10F</i>

Specification	Description
Fuzzy neural net control	Automatically learns from changes in elevator operating status to realize the optimum operation for each building.
Learning	Analyzes and stores building-internal traffic demand by time period, and automatically tunes the control parameters used for fuzzy control and the like.
Service reservation	When a hall button is pressed, the elevator hall's lantern comes on, and a single chime sounds.
Landing voice announcement system	The wait time based on group control system operation data is announced at the landing. This makes elevator usage smoother, and puts the people waiting at ease.
Peak support (assigned operation)	Separates elevators into high-floor and low-floor groups at start of business and during lunchtime, to improve transportation capacity.
High-sensitivity allocation (fuzzy control)	Forecasting and identification of operating data, using fuzzy control. Highly sensitive allocation reduces wait times.
Expert system	Specialized experience and expertise are coded into rules, and the optimum rules selected to offer service that best meets humans' psychological needs.
Program modification	Dedicated service staff can hook up a dedicated modification console to the group-control control panel in the elevator machine to modify the program according to elevator use.

## **THE GUIDELINE-2**

# **Soundproofing and harmonic distortion measures**

**We reduce noise and suppress harmonic distortion from every angle.**

**We bring together all our technologies and expertise to eliminate the impact of the elevator system.**

**As buildings become more lightweight and use space more efficiently, minimizing the sound of the running of the elevators and inside the cars has become the most vital point for building planning.**

**We aim to provide a comfortable elevator environment, whose harmonic distortion does not impact other devices.**

THE GUIDE LINE

## 2-1 Car soundproofing

There are 4 main sources of car noise: wind shear, plunge effect, air buffeting, and machine-room noise.

### 1. Wind shear

When elevators move up and down narrow shafts at high speeds, the air on the side that the car is traveling (see fig. 1 for descending car) becomes compressed. Then as the air pressure rises, the air flows through the gaps between the car and the shaft walls, to the other side of the car. As this air rushes past, it makes a low roaring sound, similar to that of an aircraft passing overhead. This sound is caused by wind shear, and the faster the car is traveling, the louder the noise will be. This sound is striking when an elevator travels at high speeds along a shaft for a single car, or two cars abreast. A particularly loud noise is perceived when two elevator cars in a two-car shaft travel abreast in the same direction. In order to reduce wind-shear noise, it is necessary to reduce the speed at which air passes through the gap between the car and the shaft walls. For example, wind-shear noise will not be generated in a single-car shaft if the elevator's rated speed is 150m/min or less, and it will not be generated in a double-car shaft if the rated speed is 180m/min or less. If speeds above this are an absolute requirement, however, please increase the area of the elevator shaft by 1.4 times the standard dimensions in P.15 (see fig. 2)

Figure 1. Cause of Wind Shear Noise

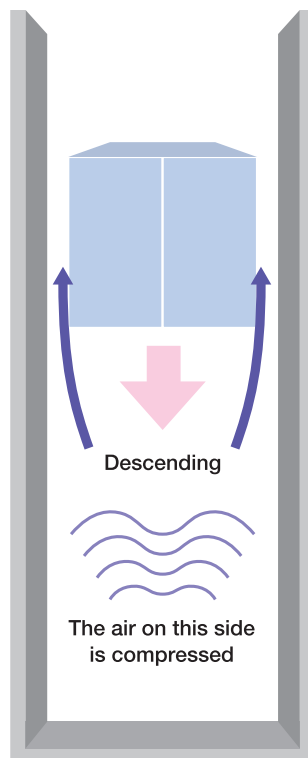

### 2. Plunge effect

- ① If multiple elevators are running abreast in a single shaft, and the path of just one of the cars is cut off midway by a wall (fig. 3 shows an example of 3 cars abreast), or if the car paths are staggered in height, then when an elevator enters this relatively more narrow space, the sudden narrowing of the passage causes the air inside the car to become compressed, generating a whooshing sound (fig. 3-①). This is plunge-effect noise. In extreme cases, the noise will be accompanied by a vibration.
- ② The plunge effect is caused by a rapid rise in air pressure. If this can be prevented, no plunge-effect noise will be generated. The best way of preventing this effect is to not create barrier walls or staggered shafts. If this cannot be avoided due to the building construction, then please implement the following countermeasures. First, creating an air outlet (see fig. 3-②) from the bottom of the barrier wall to the neighboring shaft is effective at preventing this effect. The outlet should be 1.5 to 1.8m<sup>2</sup>, and may be round.
- ③ If you cannot create an air outlet, then the shaft area must be increased 1.4-fold, as with measures against wind shear. Increasing the shaft area in a staggered shaft configuration improves the airflow in this area (fig. 4). However, there is no need for measures to prevent plunge-effect noise for a barrier walls or staggered shafts if the elevator's rated speed is 120m/min or less.

Figure 3. Causes and Measures Against Plunge Effect Noise -1

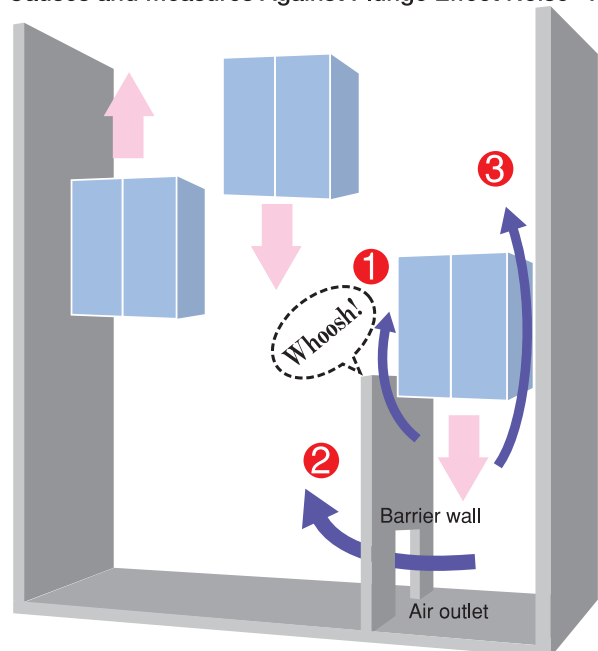
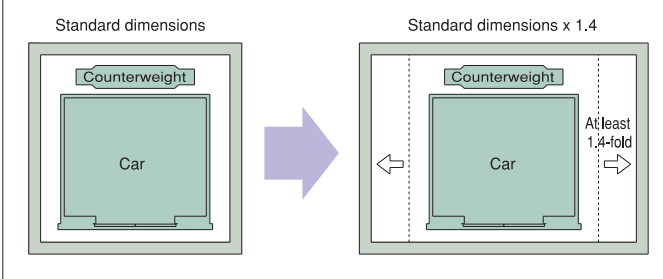
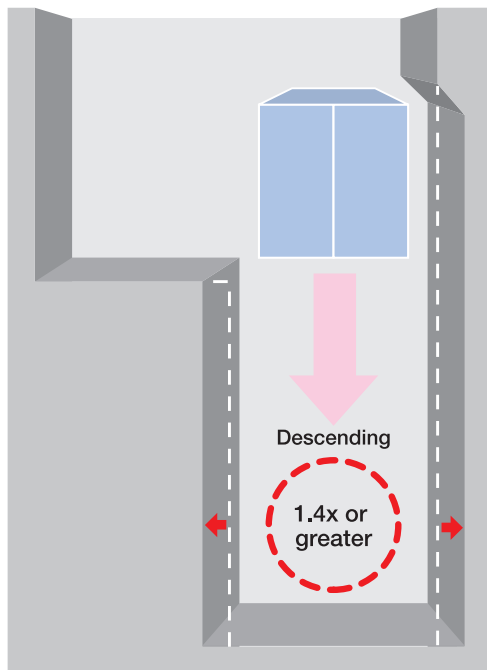

Figure 2. Measures Against Wind Shear



# Soundproofing and harmonic distortion measures

Figure 4.  
Causes and Measures Against Plunge Effect Noise-2



## ■ 3. Buffeting noise

This noise is caused when air being pushed ahead by the car in the shaft hits a protruding separator or other beam. The noise when the compressed air hits the beams sounds something like a “whap”. This is buffeting noise. In buildings with many floors, this sound is heard many times, and becomes noticeable to passengers. In order to prevent this noise, the elevator shaft should be designed with as few protruding surfaces as possible. If there are any protruding surfaces, installing sloped plates is effective at preventing this noise (fig. 5). This measure is required for single-car shafts with a speed of 150m/min or greater, and in dual-car shafts with speeds of 180m/min or greater.

## ■ 4. Machine room noise

There are several sources of machine-room noise: noise emanating from the hoist or control panel, noise from the turning of the hoist or operation of the brakes, or from the insertion of the electromagnetic contactor. This noise is transmitted into the elevator shaft by the machine-room floor and the rope (main and governor rope) holes, and can sometimes be heard from inside the car. This noise can be prevented by installing glass wool or another soundproofing material on the walls and ceilings of the machine-room, and cinder concrete (150mm or greater) on the floor. This will make the noise from the machine room equipment nearly inaudible from inside the car.

Figure 5.  
Causes and Measures Against Air Buffeting Noise

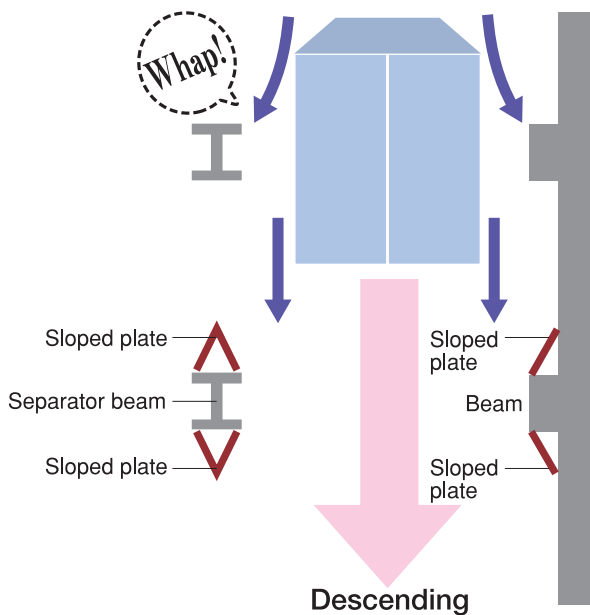
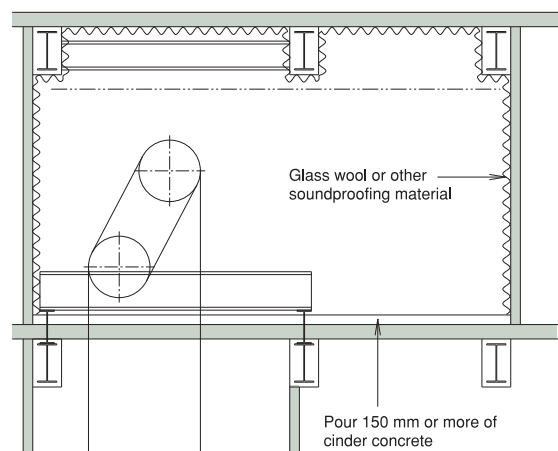

Figure 6.  
Measures against Machine Room Equipment Noise



THE GUIDE LINE

## 2-2 Noise from the elevator impacting the outside

### 1. Draft noise

When the elevator ascends and descends, a counterweight travels along rails, causing noise. The faster the elevator travels, the louder this noise. Additionally, in high-rise buildings, during the winter months warm air from the heating system flows upward due to the smokestack effect. This affects elevator shafts, since they run vertically through the building, and is particularly severe when the elevator is traveling upward. When the elevator is rising, the rising air will stream through elevator doors on floors opening to the outside, causing a high-pitched howling sound. This noise disturbs the people in the elevator hall and around the shaft of the elevator more than people in the car itself. As described above, this noise is caused when air whistles through gaps in doors and three-side frames. Although this noise can be eliminated by eliminating the gaps in doors and three-side frames, the doors require gaps in order to be opened and closed. Thus, in order to eliminate this noise, it is necessary to give sufficient consideration during the building planning stage. Building planning should take the following 3 points into account:

1. Minimize the entry of outside air into the building by using double doors with a wind-blocking antechamber at building entrances. If double-doors are not possible, then please install revolving doors.
2. Increase the shielding of each floor from outside air, since air infiltrating into the shafts escapes through gaps in the entrances on each floor.
3. Install air conditioning so that the machine-room ventilator draws air upward.

### 2. Room noise

The following two cases could cause noise from the running of the elevator to be audible from nearby rooms :

1. Wind shear from the cars can be heard through the shaft walls (air-propagated sound)
2. Sound from the moving counterweight or car is transmitted to the shaft walls via the rails or rail brackets (solid-propagated sound)

The noise from (1) is low, and almost becomes an issue. The sound from (2) can sometimes be perceived in neighboring rooms at levels as high as 50dB (A). The most important thing to do in order to prevent this noise is move the elevator shaft away from rooms susceptible to or highly impacted by noise. You should always take this into account when planning a high-speed elevator. If the shaft cannot be placed away from such rooms, then as shown in fig.7, it is effective to install the rail brackets onto separator beams or back beams, rather than directly to the wall or wall beams.

Figure 7

#### 1. When the room is behind the shaft (Back-beam insertion example)

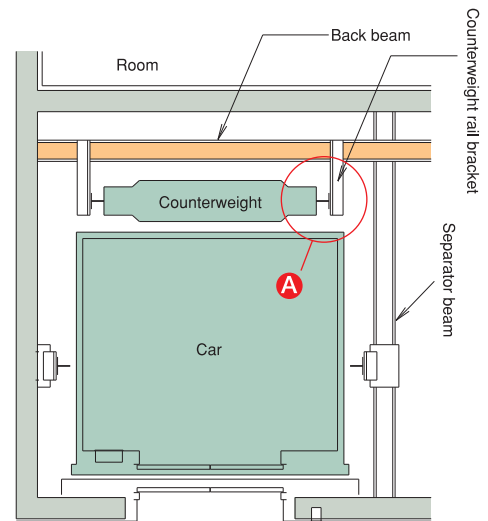

Example of fixing the counterweight rail brackets in A to a separator beam

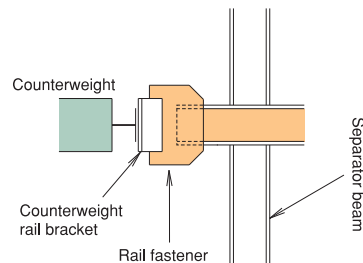

#### 2. When the room is next to the shaft (Separator beam insertion example)

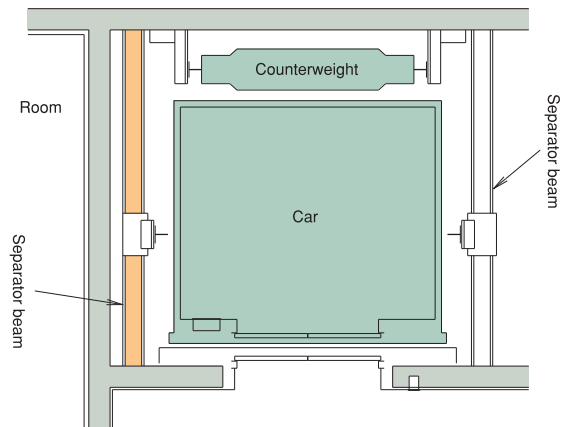

# Soundproofing and harmonic distortion measures

## ■ 3. Machine room equipment noise

Normally, the elevator's machine room is installed on the building roof, but if service for a given elevator shaft ends on a mid-level floor, then a mid or low-floor elevator machine room is installed inside the building, over that elevator shaft. If such machine rooms can be planned into the building's common space, and surrounded by storage rooms, restrooms, stairwells and the like, then machine room equipment noise will not be a particular issue. However, if the layout requires a room susceptible to or impacted by noise to be separated from the machine room by a single wall only, measures against noise must be taken. As machine-room equipment noise proceeds from the control panel, hoist, and the like, in addition to the soundproofing installed to prevent car noise, please install an airtight soundproof door in the machine room entrance. Additionally, double ceilings or walls may be installed as required.

As described below, there are measures that can be taken to prevent elevator noise inside the cars, and outside the elevator. These measures are extremely effective, and must be incorporated into the building plan. Every case of noise is different, and it is key to approach it from both the building and elevator side. We have provided support for a great number of these unique noise issues. Please consult with us if you foresee noise issues other than the ones listed above.

## ■ List of measures against elevator noise

Noise	Measure	
Car noise	Wind sheer	<ol style="list-style-type: none"> <li>(1) Avoid speeds 180 m/min or greater in single-car shafts, and speeds of 210 m/min or greater in dual-car shafts.</li> <li>(2) If the speeds in (1) cannot be avoided, then make the shaft area 1.4 times the standard dimensions listed in 3-1.</li> </ol>
	Plunge effect	<ol style="list-style-type: none"> <li>(1) Plan around using barrier walls or staggering in part of the elevator shaft.</li> <li>(2) If you must install barrier walls or stagger an elevator shaft ceiling, install a 1.5 to 1.8 m<sup>2</sup> ventilation hole in the pit of the barrier wall.</li> <li>(3) If using a staggered shaft, make the area of that shaft 1.4 times the standard dimensions listed in 3.1.</li> </ol>
	Air buffeting	<ol style="list-style-type: none"> <li>(1) Plan to minimize protrusions in the elevator shaft.</li> <li>(2) If the speed of an elevator in a single-car shaft is 150 m/min or higher, or 180 m/min or higher in a dual-car shaft, then install sloped plates over any protrusions.</li> </ol>
Noise impacting the areas outside the elevator	Machine-room equipment noise	<ol style="list-style-type: none"> <li>(1) Install glass wool or other soundproofing on the walls and ceilings of the machine room.</li> <li>(2) Pour 150 mm or more of cinder concrete on the floor.</li> </ol>
	Draft noise	<ol style="list-style-type: none"> <li>(1) Install double doors with a wind-breaking anteroom or a revolving door in the building entrance.</li> <li>(2) Shield each floor from outside air</li> <li>(3) Cool the machine-room via air conditioning</li> </ol>
	Tenant room noise	<ol style="list-style-type: none"> <li>(1) Plan the layout so that the elevator shaft is surrounded by common areas, such as storage rooms, stairwells, and the like (this is particularly essential if the elevator speed is 210 m/min or greater)</li> <li>(2) If the elevator speed is 180 m/min or less and there is no way of isolating the elevator shaft, then install separator beams on the sides of the shaft facing the room, and attach the rails to them.</li> </ol>
	Machine-room equipment noise	<ol style="list-style-type: none"> <li>(1) Plan the floor layout so that the elevator machine room is surrounded by storage rooms, stairwells, and the like.</li> <li>(2) If (1) is not possible, please consult with us. <ol style="list-style-type: none"> <li>A. Install an airtight, soundproof door on the machine-room entrance</li> <li>B. Apply soundproofing material to the walls and ceiling</li> <li>C. Use double walls and ceilings</li> </ol> </li> </ol>

THE GUIDE LINE

## 2-3 Measures against harmonic distortion

Although inverter-control elevators feature high-performance, high energy efficiency, and other benefits, they use high-speed switching elements, which generate harmonic distortion when operating, which could impact telecommunications and office-automation equipment. Please take the following measures to avoid impact from harmonic distortion.

1. Install the elevator drive power transformers away from the transformers of telecommunications devices, office automation equipment, and other low-power electronic devices.  
If you draw power for low-power electronic devices from the same transformer as the drive power, the harmonic distortion generated by the elevator could cause condition noise, impacting the low-power electronic devices.
2. Keep elevator drive power lines at least 1m away from the power lines and communications lines of low-power electronic devices.  
Electromagnetic and electrostatic induction is effective at reducing noise. If it is not feasible to keep the lines separated, then separate the drive power lines from the lines of the low-power electronic devices using a steel shielding plate.
3. Do not install elevator power lines in the ceilings or floors near low-power electronic devices.  
Electromagnetic and electrostatic induction is effective at reducing noise. Avoid cabling near low-power electronic devices, and keep lines as short as possible.
4. Avoid using the same earth for low-power electronic devices. Conduction, and electromagnetic and electrostatic induction are effective at reducing noise.
5. If you install a residual current operated circuit breaker or electric leakage magnetic relay, use one with inverter support in order to avoid excessive operation.  
Inverter-control elevators release leak current, which causes excessive operation by residual current operated circuit breakers and electric leakage magnetic relays. Please use an inverter-compliant product that does not operate needlessly in the high-frequency range.

### Sample earth line layout

Example of earths to avoid

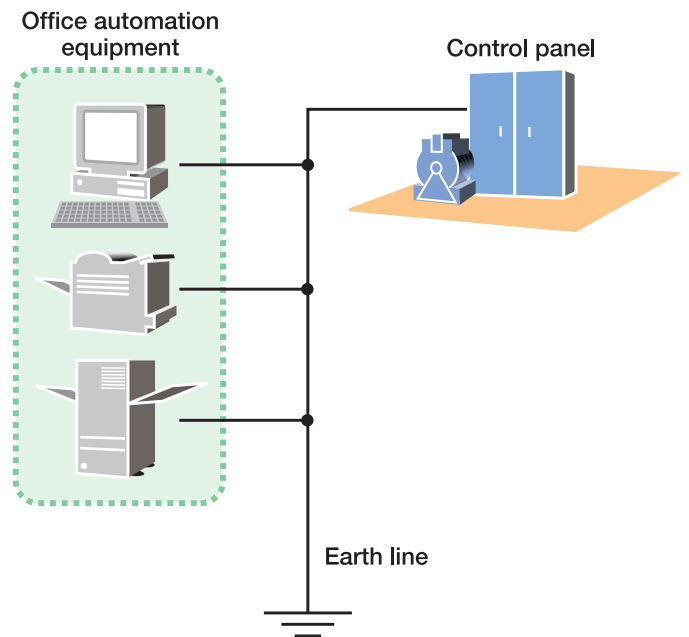

Example of effective earth

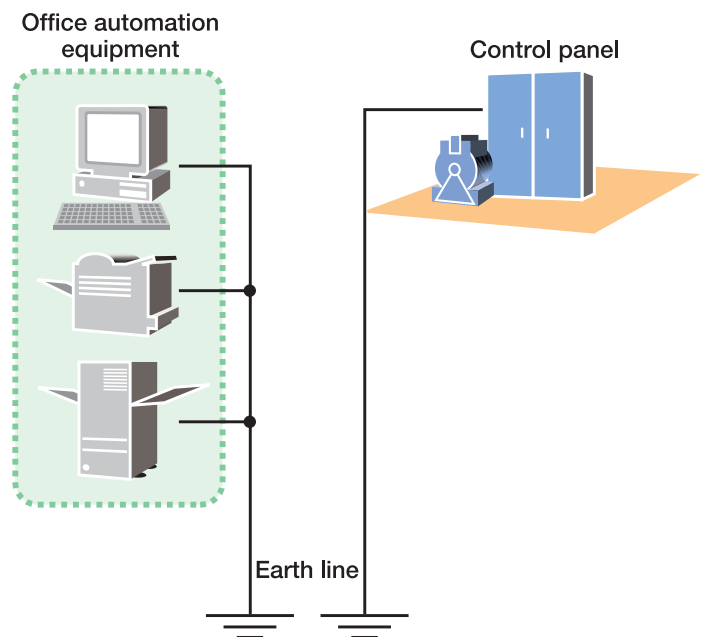

# Installation plan / Power facility plan

## 3-1 Installation plan <Standard type>

### Installation diagram for 8 to 24 passenger

#### ■ Hoist-way plan

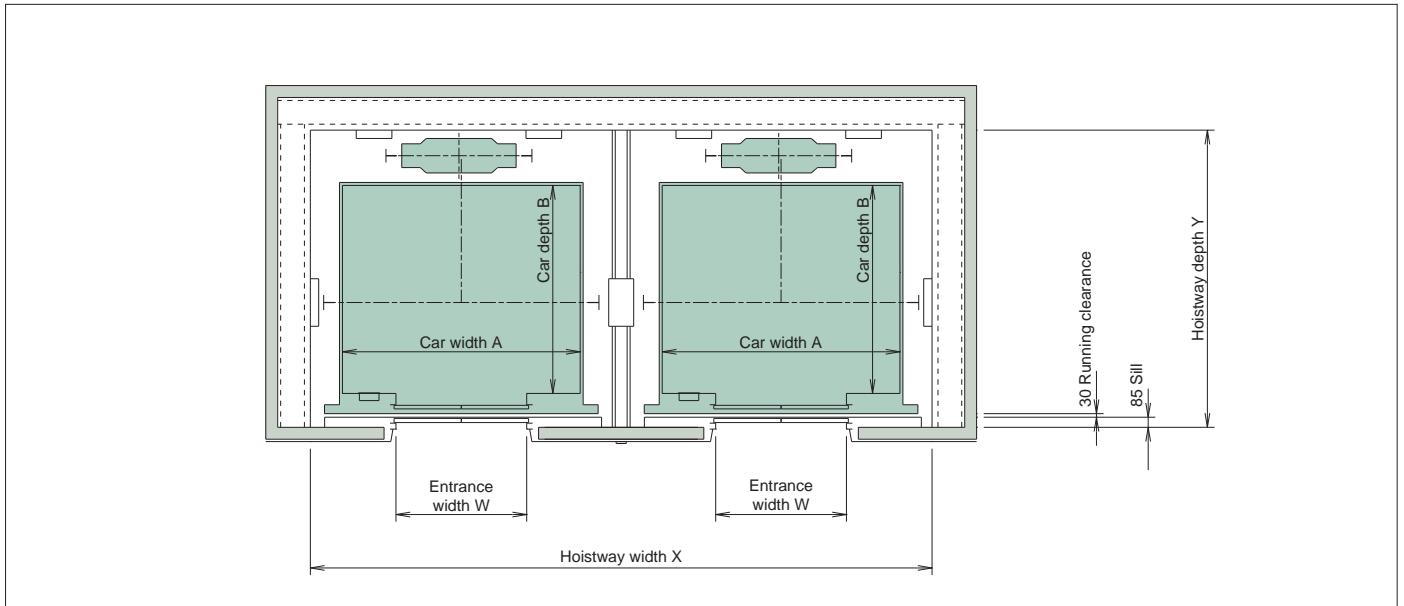

#### ■ Machine-room plan

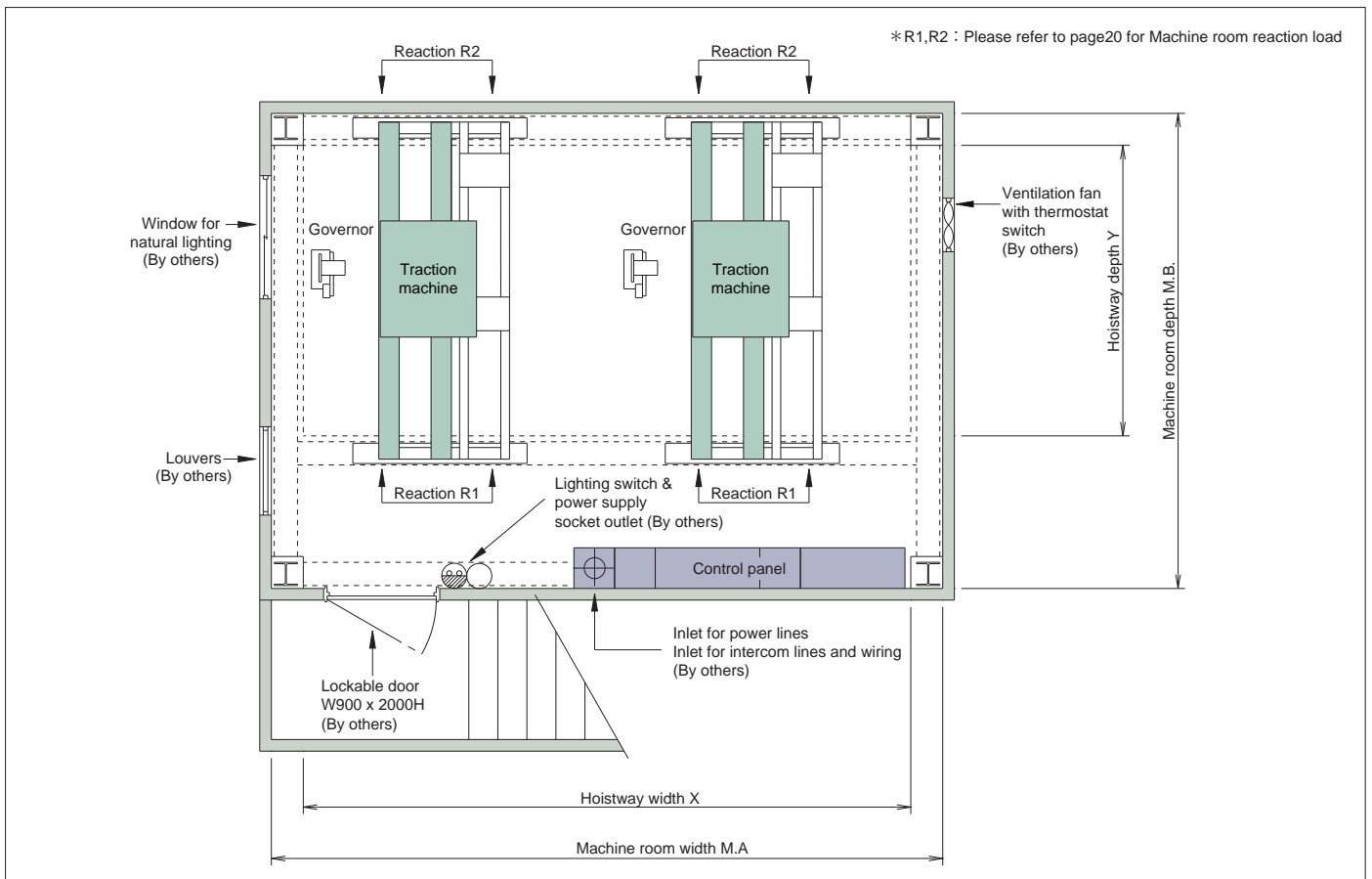



## ■ Shaft and machine room dimensions (Floor plan dimensions)

Rated speed (m/min)	Type	Entrance (mm)		Internal car dimensions (mm) A×B	Shaft (mm)				Machine room (mm)			
		Width	Height		Single shaft* X x Y	Dual shaft** X x Y	Triple shaft X x Y	Quadruple shaft X x Y	Single shaft* MA x MB	Dual shaft** MA x MB	Triple shaft MA x MB	Quadruple shaft MA x MB
120	P8-CO	800	2100	1400×1100	1940×1925	4030×1925	6120×1925	8210×1925	2350×3400	4500×3400	7000×3400	9150×3400
	P12-CO	900	2100	1600×1350	2140×2175	4430×2175	6720×2175	9010×2175	2500×3650	4800×3650	7450×3650	9750×3650
150	P13-CO	900	2100	1600×1500	2140×2325	4430×2325	6720×2325	9010×2325	2500×3800	4800×3800	7450×3800	9750×3800
180	P15-CO	1000	2100	1800×1500	2340×2325	4830×2325	7320×2325	9810×2325	2700×3800	5200×3800	8050×3800	10550×3800
210	P18-CO	1000	2100	2000×1500	2540×2325	5230×2325	7920×2325	10610×2325	2900×3800	5600×3800	8650×3800	11350×3800
240	P21-CO	1100	2100	2000×1700	2540×2525	5230×2525	7920×2525	10610×2525	2900×4000	5600×4000	8650×4000	11350×4000
	P24-CO	1200	2100	2100×1750	2640×2575	5430×2575	8220×2575	11010×2575	3050×4050	5900×4050	9100×4050	11950×4050

\* In order to prevent noise in the car for a single-shaft elevator with a speed of 180 m/min or greater, increase the dimensions of the shaft X and machine room MA.

\*\* In order to prevent noise in the car for a double-shaft elevator with a speed of 210 m/min or greater, increase the dimensions of the shaft X and machine room MA.

Note: Please contact us for detailed dimensions.

# Installation plan / Power facility plan

## 3-2 Installation plan <Compact machine room type>

### Installation diagram for 8 to 24 passenger

#### ■ Hoist-way plan

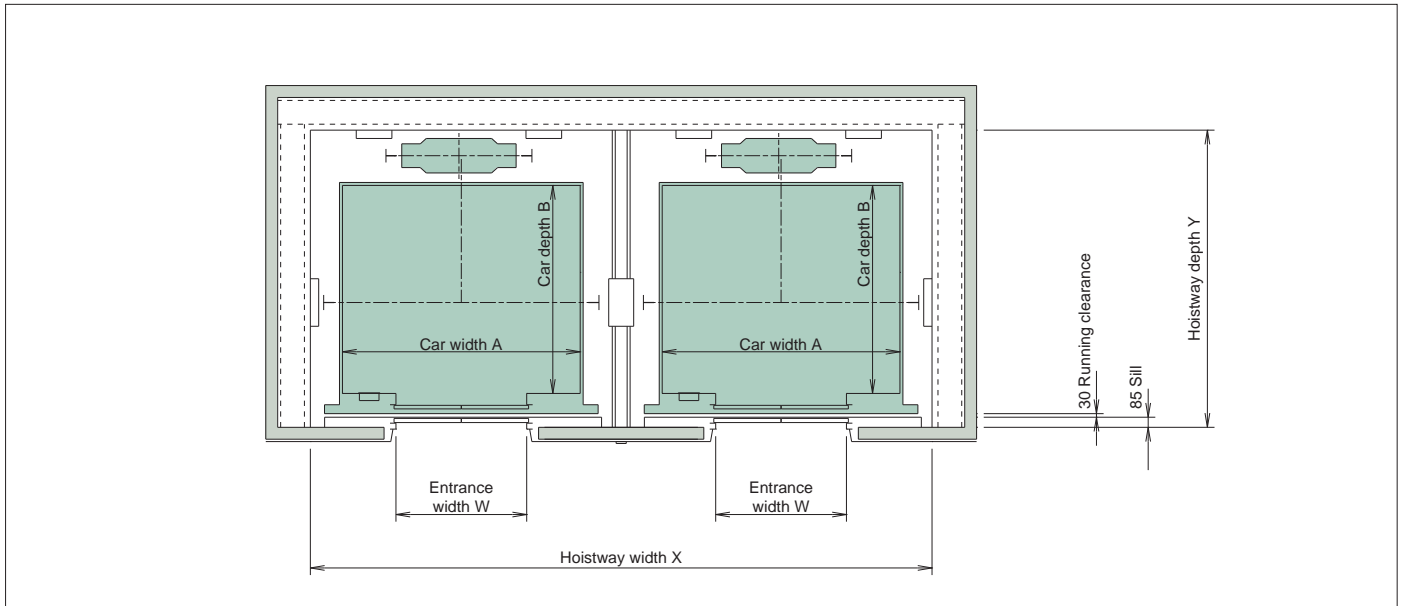

#### ■ Machine-room plan

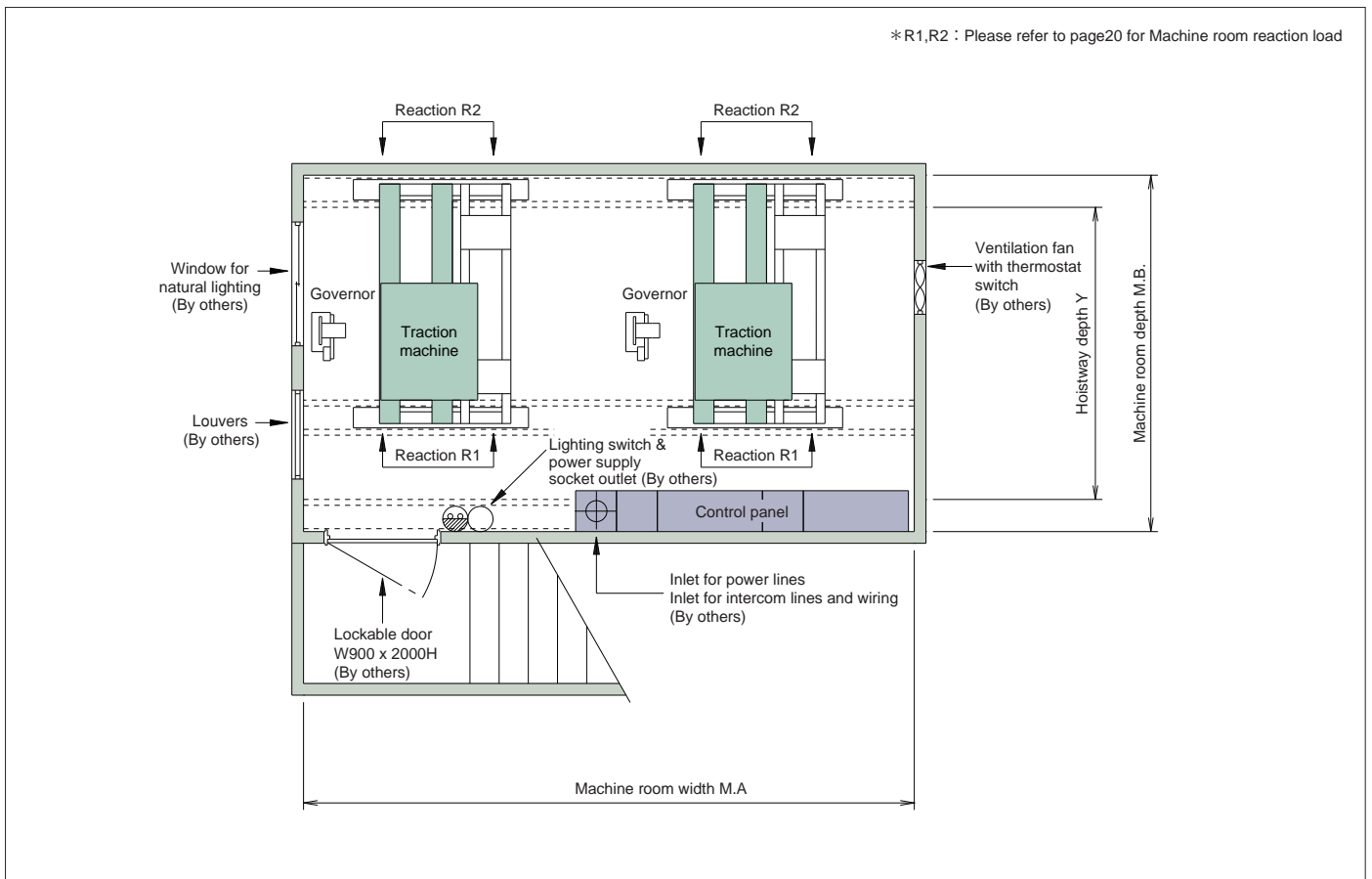

## ■ Shaft and machine room dimensions (Floor plan dimensions)

Rated speed (m/min)	Type	Entrance (mm)		Internal car dimensions (mm) A×B	Shaft (mm)				Machine room (mm)			
		Width	Height		Single shaft* X x Y	Dual shaft** X x Y	Triple shaft X x Y	Quadruple shaft X x Y	Single shaft* MA x MB	Dual shaft** MA x MB	Triple shaft MA x MB	Quadruple shaft MA x MB
120	P8-CO	800	2100	1400×1100	1940×1925	4030×1925	6120×1925	8210×1925	2100×2750	4230×2750	6370×2750	8610×2750
	P12-CO	900	2100	1600×1350	2140×2175	4430×2175	6720×2175	9010×2175	2250×2850	4430×2850	6720×2850	9010×2850
150	P13-CO	900	2100	1600×1500	2140×2325	4430×2325	6720×2325	9010×2325	2250×2950	4430×2950	6720×2850	9010×2950
180	P15-CO	1000	2100	1800×1500	2340×2325	4830×2325	7320×2325	9810×2325	2700×2950	5200×2950	8050×2950	10550×2950
210	P18-CO	1000	2100	2000×1500	2540×2325	5230×2325	7920×2325	10610×2325	2900×2950	5600×2950	8650×2950	11350×2950
240	P21-CO	1100	2100	2000×1700	2540×2525	5230×2525	7920×2525	10610×2525	2900×3050	5600×3050	8650×3050	11350×3050
	P24-CO	1200	2100	2100×1750	2640×2575	5430×2575	8220×2575	11010×2575	3050×3050	5900×3050	9100×3050	11950×3050

\* In order to prevent noise in the car for a single-shaft elevator with a speed of 180 m/min or greater, increase the dimensions of the shaft X and machine room MA.  
 \*\* In order to prevent noise in the car for a double-shaft elevator with a speed of 210 m/min or greater, increase the dimensions of the shaft X and machine room MA.  
 Note: Please contact us for detailed dimensions.

# Installation plan / Power facility plan

## 3-3 Hoistway section

### ■ Hoistway section <Standard type>

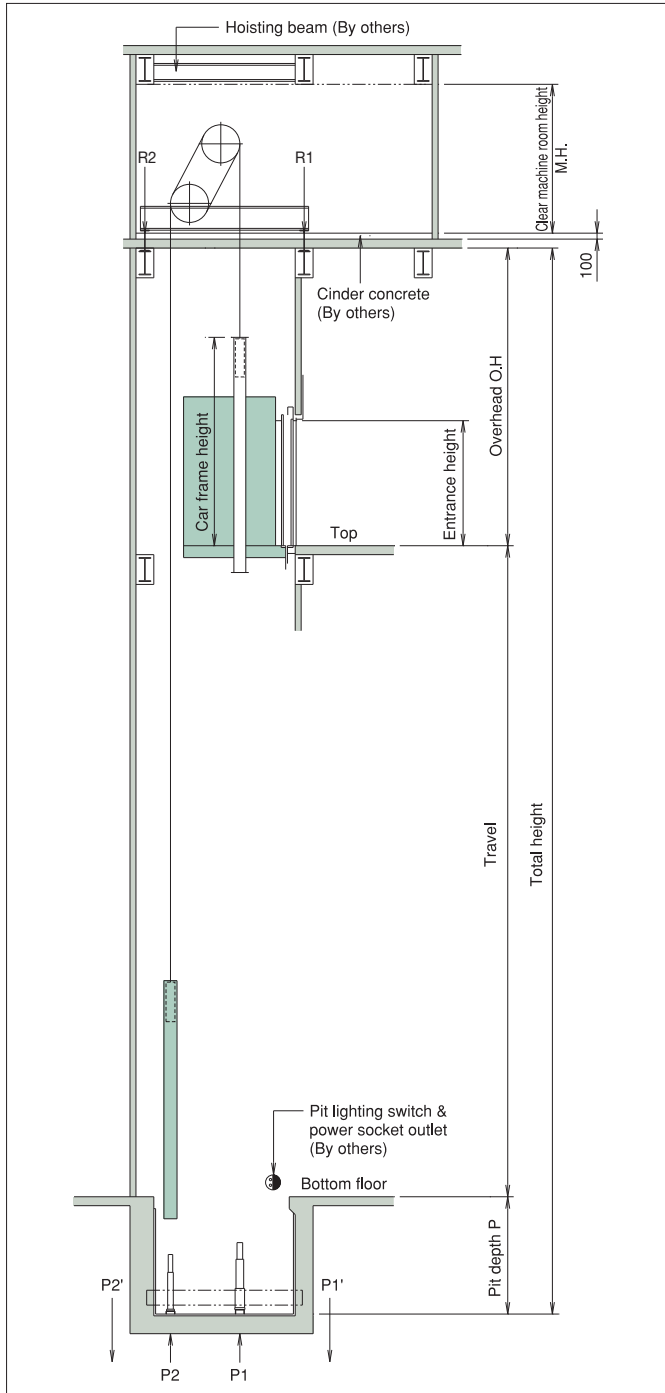

### ■ Hoistway section <Compact machine room type>

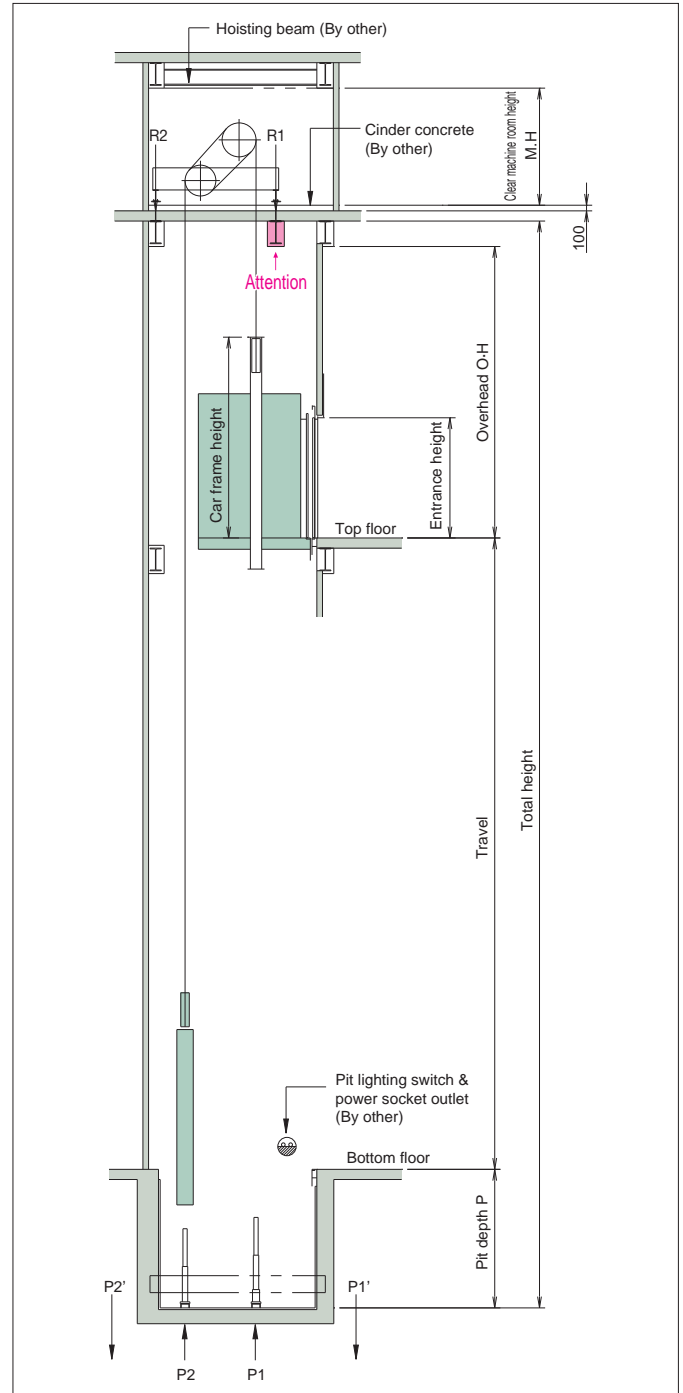

Note :

When car safety is suddenly actuated or when car strikes against buffers during high-speed operation, the counterweight will jump up. Likewise when the counterweight safety (where provided) is actuated or when it strikes the buffer, the car will also jump up.

Hence for the elevators with speed of 240m/min or higher, tie-down safety device is provided at the compensating sheave to reduce the jumping effect of the car and counterweight by absorbing the jumping energy into the springs of the tie-down safety and elastic strain energy of the compensating ropes.

## ■ Shaft & Machine room dimensions (Cross section dimensions)

Rated speed (m/min)	Overhead		Pit depth	Clear machine room height
	O.H(mm)		P(mm)	M.H(mm)
	P8,P12	Other		
120	5950	5350	2150	2250
150	6150	5550	2450	
180	6450	5850	2750	
210	6850	6250	3250	
240	7450	6850	3850	

Note: Dimensions are displayed with a leeway of 50 mm. Impact force applied to machine-room reactive-force pit, force applied to tie-down safety, and force applied to machine-room ceiling trolley beam.

## ■ Machine room reaction, pit reaction, tie-down safety and hoisting beam load.

Type	Rated speed (m/min)	Machine room reaction load (kN)				Pit reaction load (kN)		Tie-down safety reaction load (kN)		Hoisting beam load (kN)		
		Standard type		Compact machine room type								
		R1(Cage)	R2(C/W)	R1(Cage)	R2(C/W)	P1(Cage)	P2(C/W)	P1'(Cage)	P2'(C/W)			
P8-CO	120	95.5	132.5	134.0	94.0	194.0	172.5	-	-	54.0		
	150					201.5	180.0					
	180										195.5	173.5
	210										219.5	199.5
P12-CO	120	106.0	147.0	153.0	99.5	211.5	184.0	-	-			
	150					226.5	199.0					
	180										220.0	192.5
	210										226.5	199.0
P13-CO	120	107.5	150.5	157.5	100.5	225.0	195.5	-	-			
	150					232.5	203.0					
	180										226.0	196.5
	210										232.5	203.0
P15-CO	120	110.5	154.5	162.5	102.5	232.5	200.5	-	-			
	150					240.5	208.0					
	180									234.0	201.5	
	210									240.5	208.0	
P18-CO	120	115.0	161.0	168.5	107.5	244.5	208.5	-	-			
	150					252.0	216.0					
	180									245.5	209.5	
	210									252.0	216.0	
P21-CO	120	123.5	173.0	183.0	113.5	265.5	224.5	-	-			
	150					273.5	232.0					
	180									266.5	225.5	
	210									273.5	232.0	
P24-CO	120	128.5	179.0	190.0	117.5	277.5	232.0	-	-			
	150					285.0	240.0					
	180									278.5	233.0	
	210									285.0	240.0	

Values may differ slightly, depending on car design and car-room size. Please contact us for details.

## ■ Attention <Compact machine room type>

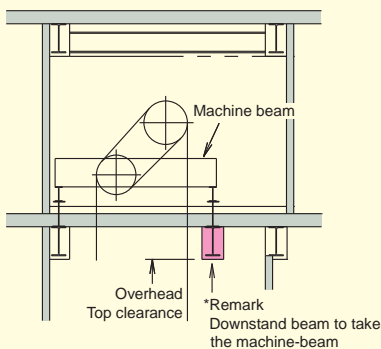

- ① Provision of a downstand beam is necessary to take the loading
- ② Please ensure sufficient clearance for overhead and top clearance
- ③ Please consult the structural engineer on the design of the downstand beam.
- ④ Downstand beam to be provided by others.

# Installation plan / Power facility plan

## 3-4 Power facility plan

### Power facility plan for 8 to 24 passenger

#### ■ Single elevator use (1 line per elevator) 380v-50Hz

Model	Rated speed (m/min)	Motor capacity (kW)	Motor source capacity (kVA)	Non-fuse circuit breaker (A)	Total applicable length of the power source line (m)					Grounding line size (mm <sup>2</sup> )	Heat generation (W)
					5.5 (mm <sup>2</sup> )	8 (mm <sup>2</sup> )	14 (mm <sup>2</sup> )	22 (mm <sup>2</sup> )	38 (mm <sup>2</sup> )		
P8-CO	120	8	14	40	58	90	160	250	423	3.5	2050
	150	10	16	40	46	71	126	198	334	3.5	2600
	180	12	18	40	38	58	104	163	276	3.5	3100
	210	14	20	50	32	50	90	141	238	3.5	3600
	240	16	22	50	28	44	78	122	207	3.5	4100
P12-CO	120	12	18	40	50	77	138	215	364	3.5	3100
	150	14	21	50	39	61	109	170	288	3.5	3850
	180	18	25	60	33	51	91	142	241	5.5	4600
	210	20	28	60	-	40	77	120	203	5.5	5400
	240	22	31	75	-	35	67	105	177	5.5	6150
P13-CO	120	12	19	50	48	74	133	208	351	3.5	3450
	150	16	23	50	38	58	104	163	276	3.5	4300
	180	18	27	60	-	45	86	135	228	5.5	5150
	210	22	30	75	-	38	74	115	195	5.5	6000
	240	24	34	75	-	-	59	99	168	5.5	6850
P15-CO	120	14	22	50	45	70	124	195	329	3.5	3950
	150	18	26	60	-	52	99	155	262	5.5	4900
	180	22	30	60	-	42	81	128	216	5.5	5900
	210	26	34	75	-	-	64	108	183	5.5	6850
	240	28	38	100	-	-	55	93	158	5.5	7850
P18-CO	120	18	25	60	41	65	115	180	305	5.5	4600
	150	22	29	60	-	47	91	142	241	5.5	5750
	180	26	34	75	-	-	70	118	199	5.5	6900
	210	30	39	100	-	-	60	101	171	5.5	8050
	240	34	44	100	-	-	51	86	146	5.5	9200
P21-CO	120	20	28	60	-	55	106	166	280	5.5	5450
	150	24	34	75	-	-	77	130	220	5.5	6850
	180	30	40	100	-	-	64	107	182	5.5	8200
	210	34	45	125	-	-	54	91	153	8	9550
	240	40	51	125	-	-	46	78	133	8	10900
P24-CO	120	22	31	75	-	52	100	157	266	5.5	6150
	150	28	38	100	-	-	73	122	207	5.5	7700
	180	34	44	100	-	-	59	100	170	5.5	9200
	210	38	51	125	-	-	51	85	145	8	10750
	240	44	57	125	-	-	-	69	125	8	12300

## Works by others

### Works below are not included in installation works of elevator:

#### ■ Hoistways

1. Hoistway construction and fire-proofing work, and opening work for jambs, indicators and push-buttons, etc.  
Please note that chipping or padding work is required according to the necessity, in case the error of the structure is 30 mm or over.
2. Installation work of separating beams, intermediate beam, back beam and lateral beams (If necessary).
3. Installation work of the base plate for each floor and of bed steel for furnishing the equipments related to landing entrance, in case of hoistways of steel structure of PC structure.
4. Fire-proofing work of steel frame material in steel structured hoistways, and fire-proofing work around landing entrances (If necessary).
5. Finishing works of walls and floors, etc., around entrances, after furnishing equipments related to landing entrances.
6. Furnishing work of base steel or others for furnishing rail brackets, especially in case the floor height is high (if necessary).
7. Installation work of the entrance or the gangway for pit inspection (if necessary).
8. Water-proofing work of the pit (including drainage if necessary).
9. Re-arrangement of the building body in case that there are some spaces to be used under the pit.
10. Installation work of emergency exits for rescue purposes in the event there are floors at which the elevator does not stop and installation of a fascia plate.
11. Shelter equipments from rain at landing entrances directly contacting to the air in the place like roof.
12. Installation work of hooks or beams on top of the elevator shaft.
13. Installation work of lighting in hoistway (If necessary).
14. Installation work of vent opening at the top of shaft (If necessary).
15. Installation work of a net or wall to prevent falling into the pit (in case of pit level is different.)
16. All works related to the building structure other than works above.

#### ■ Machine rooms

1. Construction work of machine-rooms and installation works of their entrances (including sound proofing work if necessary)
2. Fire-proofing work for machine rooms and opening work for machine room floors.
3. Installation work of machine beam supports and spacers.
4. Cinder concreting and its finishing work after floor piping in machine rooms.
5. Installation work of hooks or beams on ceilings in machine rooms.
6. Installation work of stairs leading to machine rooms and stairs in machine rooms (if necessary)
7. Installation work of lighting windows.
8. Dust-proof finish of the floor.

#### ■ Works for Equipments

1. Wiring work of the power supply for motors and that for lighting equipments, and of grounding to power source panels of elevators in the Elevator shaft.
2. Wiring work of the power supply to the supervisory panels.
3. Piping and wiring works of interphones outside hoistway and of others necessary for elevators.
4. Supply and installation of switching devices for emergency power supply at the power failure and two pairs of relay contacts for normal / emergency power identification, and their piping and wiring work (if necessary).
5. Piping and wiring work of supervisory panels, alarm panels and inter-communication systems, etc., outside hoistways.
6. Furnishing work of receptacles for inspection in pits.

#### ■ Temporary Works

It is required to arrange the following matters:

1. To secure the site office for installation work, and the stock yard for materials without charge.
2. Enclosure to be used during the installation work.
3. Supply of electric power for installation work and the trial operation for adjustment.
4. Security of enough passage for carrying heavy goods.
5. On use of elevator for the construction work of the building, it is required to make contract with a separate written estimate.

#### Note

At equipment planning of elevators, please take the following items into consideration:

1. Provide the power facility so that the voltage regulation of power supply at the receiving terminals in the hoistway is kept within  $\pm 10\%$  for motor, and  $\pm 2\%$  for lighting equipments.
2. In the hoistways, please avoid allowing the temperature exceed  $40\text{ }^{\circ}\text{C}$  and humidity exceed  $90\%$  (monthly mean) and  $95\%$  (daily mean).
3. Please do not allow such chemically toxic gas or excess amount of dust enter into the hoistways, that makes the metal or electrical contacts corrode.

#### At inquiry of the estimate, please inform us of the following:

1. Building name and address.
2. Desired type and number of set.
3. Number of stops.
4. Floor height.
5. Voltage and frequency of main power supply.
6. Desired completion date.



## Safety Cautions

- Observance of relevant laws / regulations are required.
- Read the entire "Instruction Manual" carefully before use, for important information about safety, handling and operation.

**TOSHIBA**

**TOSHIBA ELEVATOR AND BUILDING SYSTEMS CORPORATION**

5-27, Kitashinagawa 6-chome, Shinagawa-ku,  
Tokyo 141-0001 Japan  
PHONE: +81-3-5423-3389 FAX: +81-3-5423-2746

- The data given in this catalog are subject to change without notice.