

PRODUCT DATA SHEET

LIGHTNING PROTECTION AND EARTHING SYSTEM COMPONENTS

Code: 64 47 253

Description: 25x3mm PVC coated aluminium tape conductor

ed.03/2021

Application

Aluminium tape used as air termination conductor and down conductor.

Technical characteristics

Width	25 mm
Thickness	3 mm
Cross sectional area	75 mm ²
Material	Aluminium (Al)
Insulation material	PVC
Insulation color	White
Electrical resistivity	≤0,036 μΩm
Tensile strength	120 – 280 N/mm ²

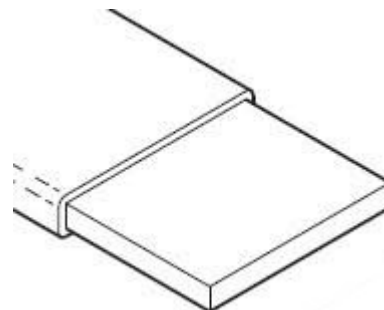

Installation instructions

Installation	Above ground
Can be connected with	Al, Stainless Steel (SSt), St/tZn

Comply with

The component complies with standard IEC EN 62561-2 "Lightning protection system components (LPSC) – Part 2 : Requirements for conductors and earth electrodes".

Manufacturing Quality Control

Manufacturing quality control according standard ISO 9001

Country of Origin

Greece

Needed accessories¹⁾

Clamps (e.g. 6201833), fasteners (e.g. 6177253) for the spacing consult fasteners' installation instructions.

Unit: meter

¹⁾ See relevant data sheets

We reserve the right to introduce changes in the component due to technical evolution.