

## PRODUCT DATA SHEET

### LIGHTNING PROTECTION AND EARTHING SYSTEM COMPONENTS

**Code: 60 13 005**

ed.01/2020

**Description: Set of two bases for air termination rod mast**

#### Application

Base for air termination rod mast, made out from hot dip galvanized steel (St/tZn). Two bases are required for the mast support. The mast is fastened to each base through U-bolt fastener (part numbers ELEMKO 60 04 033 or 60 04 040 or 60 04 048 – not included).

#### Technical characteristics – Installation instructions

Material	Hot dip galvanized steel (St/tZn)	
Can be connected with	Al, SSt (stainless steel), St/tZn	
Supplied accessories (4 pieces each)	M12x140 mm St/eZn anchor	
	M12x60 mm St/tZn hexagon head screw	
	M12 St/tZn nut	
	M12 St/tZn washer	
Distance between bases according to the height of mast	Height of mast (mm)	Bases' distance (mm)
	3000	500
	6000	800
	7000	800

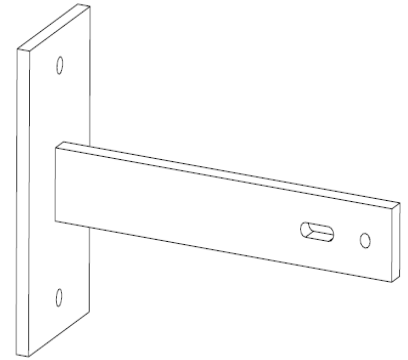

#### Manufacturing Quality Control

Manufacturing quality control according standard ISO 9001

#### Country of Origin

Greece

#### Unit: piece / Package: 1 piece

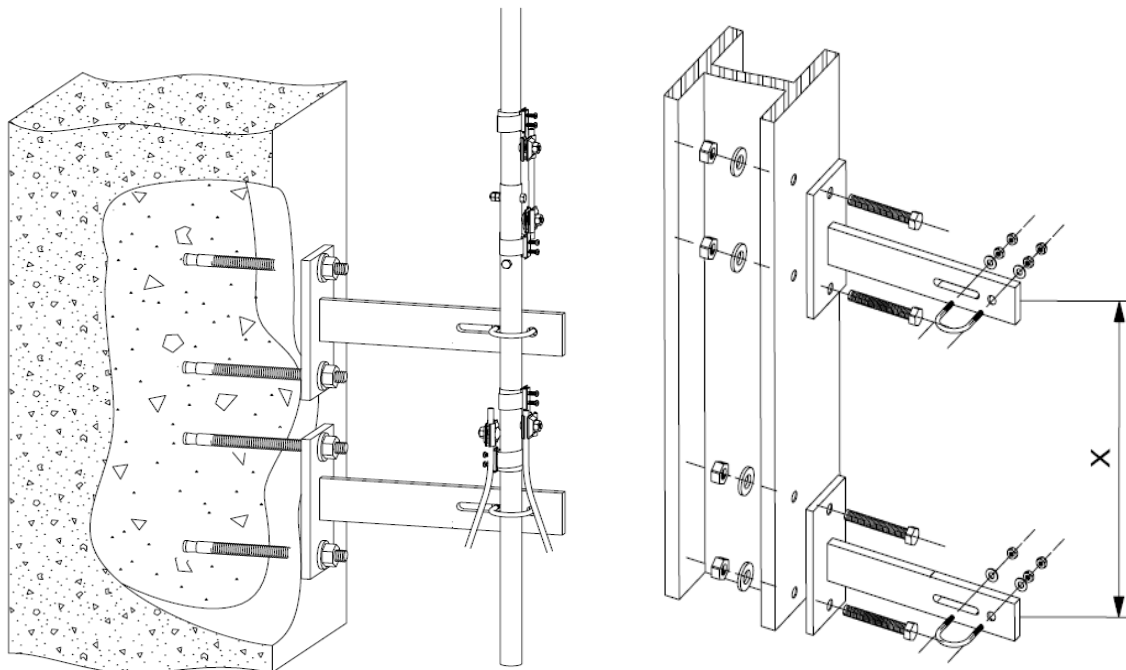

We reserve the right to introduce changes in the component due to technical evolution.